

# Exclusive Line



**WCVent**<sup>®</sup>  
AIR EXTRACTORS

**An Effective Air Solution with Style**

Our Exclusive Line has been designed and manufactured to the highest quality standards.

# MANUAL

Air extractors are essential components for ensuring proper air circulation and ventilation within enclosed spaces.

**The product is only installed on 12.5mm gypsum boards.**

<b>Q(m<sup>3</sup>/h)</b>	50-200
---------------------------	--------

**Package includes the following parts:**

**a** AIR EXTRACTOR

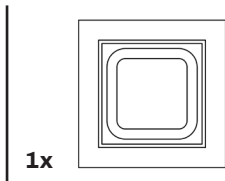

**b** ASSEMBLY & INSTALLATION  
SCREWS 35mm



**c** VENTUS SPIGOT

**NOT INCLUDED**



Ventus spigot can be purchased separately. The product has a  $\varnothing 125$  hole. Possible option of reducing the size by a  $\varnothing 100$  (ref. code 100A) spigot.

## **1** ASSEMBLY INSTRUCTIONS

### Step 1

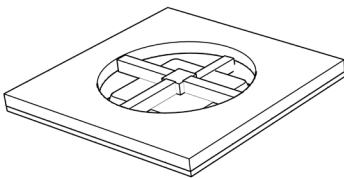

### Step 2

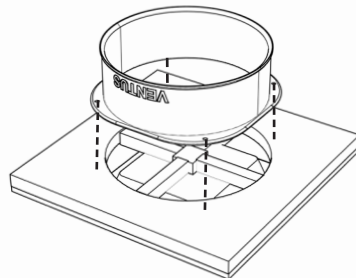

### Step 3

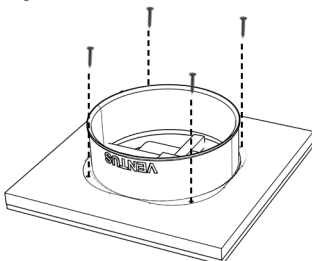

## 2 INSTALLATION PROCESS

### Step 1

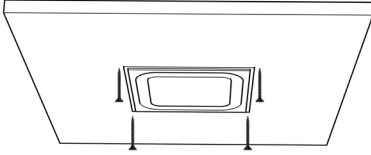

### Step 2

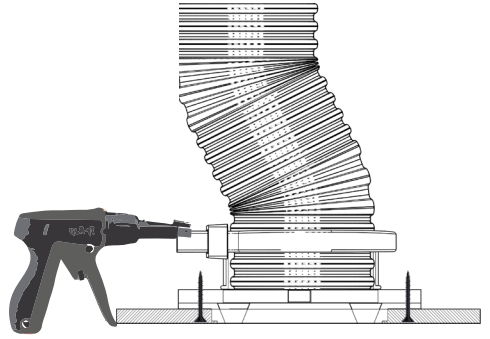

## 3 FINISH PROCESS

### Step 1

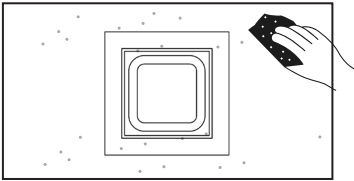

### Step 2

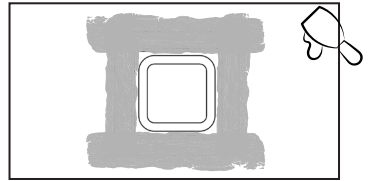

### Step 3

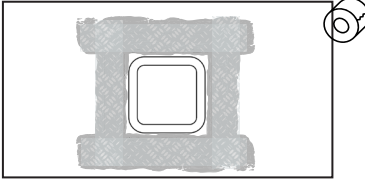

### Step 4

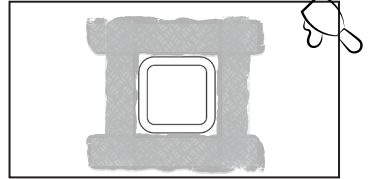

### Step 5

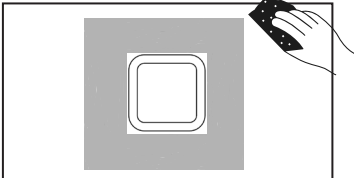

### Step 6

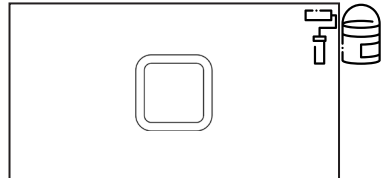

## DISASSEMBLY INSTRUCTIONS

### Step 1

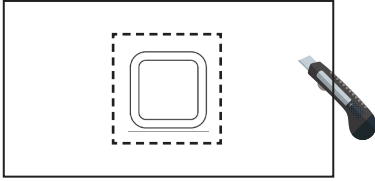

### Step 2

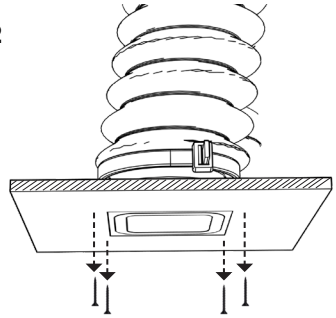

### Step 3

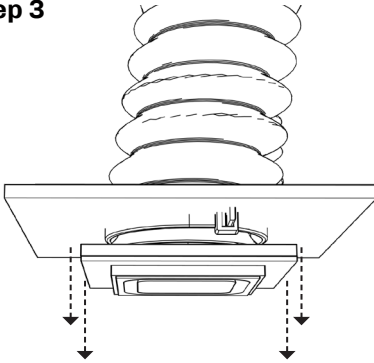

### Step 4

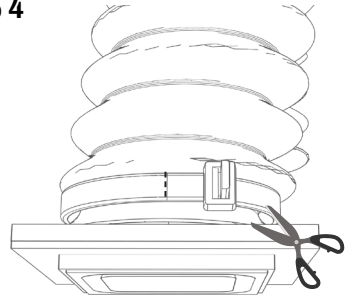

### Step 5

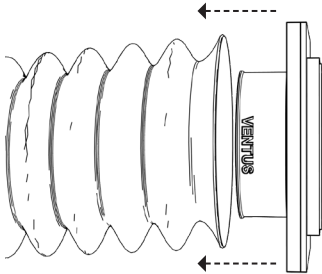

### Step 6

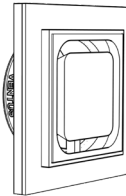

**Give Your Product a New Life!**

**All D.Ellinas products are designed to be disassembled for either reuse or recycling.**

[www.wcvent.com](http://www.wcvent.com)

Copyright © WCvent Air Extractors® is a brand of D.Ellinas Factory Products Ltd®, protected by European and International laws pertaining to intellectual property.

D.Ellinas Factory Products is a registered company in Cyprus (reg. no. HE260375)